



CONVECTION STEAMER
eco**combi**

ONE DESIGN – MANY OPTIONS!



Model HECME4

4 x 1/1 GN



ECOCOMBI SIMPLE, STURDY AND RELIABLE

- **Premium quality and reproducible cooking results**
Perfect and reproducible cooking results every single day
- **Flexibility (GN and EN insertion)**
Highly adaptable to the different requirements
- **Easy to clean**
Optimised cleaning programme
- **Operating comfort**
Basic-Touch display with practical and intuitive icons
- **Low-maintenance, high reliability**
Maintenance and operating costs are reduced to a minimum



Model HECME6

6 x 1/1 GN



Model HECME10

10 x 1/1 GN

MANUAL OPERATION, OR VIA MIT PROGRAMMES

With its options for setting cooking parameters or selecting recipes, the **ecomcombi** ensures constant control and optimum cooking results – whether it is operated by the head chef or by the apprentice.

SOUS-VIDE COOKING

Thanks to accurately controlled low temperatures and steam volumes, food cooked sous-vide is particularly moist, juicy and delicious. With minimum weight loss, the valuable nutrients and the natural aroma are preserved.

GENTLE COOKING

The accurate temperature control in all cooking processes ensures minimum weight loss and optimum taste. Perfect for slow cooking, also over night.

PERFECT PASTRY AND BREADS

Thanks to the even distribution of heat and humidity in the cooking chamber, the convection steamer bakes tender, flaky pastry and crusty breads.

FAST REGENERATION

Since the **ecomcombi** reaches the ideal serving temperature very quickly, quality loss is avoided. You can be sure that your meals will always be served piping hot.



EXCELLENT RESULTS

Excellent and uniform results

Excellent heat distribution in the cooking chamber thanks to:

- reversing fan impeller
- 6-stage speed control
- 70 mm guide rail distance
- crosswise insertion



Achieving the best cooking results and being able to reproduce them every day is the precondition for optimum performance. The sophisticated **ecocombi** technology and multi-functionality offers the perfect solution for the various requirements in the professional kitchen:

AHC - Active Humidity Control. Measuring and controlling the humidity inside the cooking chamber. Easy to set, accurate and reproducible in daily operation.

EUR - Excellent Uniformity Results. Optimum heat distribution inside the cooking chamber is ensured by:

- **Fan reversal:**
For optimum heat distribution inside the cooking chamber.
- **6 fan speeds:**
Allow you to adjust the heat distribution to every type of food, from the pastry to the restaurant meal.
- **Loading height 70 mm:**
70 millimetre distance between the rails ensures even cooking and perfect distribution of the hot air inside the cooking chamber.

EASY OPERATION

Sensitive display EcoPAD

The user-friendly, simple operation makes work processes more efficient, and the lives of the chef and his or her team easier.

START ANY TYPE OF COOKING PROGRAMME
with 3 simple steps.

CLEAR AND INTUITIVE SYMBOLS
make every command easy to understand.

UP TO 60 RECIPES WITH 5 PHASES
ecomcombi gives the chefs everything they need.

USB PORT
Allows the chef to save or download recipes,
to check HACCP data, and to update the software.



COMFORTABLE FLEXIBILITY

Smart Upgrade Pack

SMART UPGRADE PACK

- Humidity control kit
- Cleaning system kit
- Internal/external core temperature sensor kit
- USB kit

Professional kitchen equipment must be flexible to adapt to the constantly increasing requirements.

All features of the ecocombi convection steamer can be upgraded – also at a later date.

Also after purchase and installation, the **ecocombi** can be extended by one of the kits of the Smart Upgrade Pack. It can be configured on site to match your requirements. From the Basic model to the full-scale version – without any problems.



SMART SERVICE SOLUTIONS

The **ecocombi** is easy to install and to service.

Service solutions:

- Front access to the display and CPU circuit board
- Faster installation
- Self-explanatory fault messages
- 90% of the components are accessible from the right side panel



Smart Wash system with Magic Ball

A simple cleaning system which is instantly available.

SMART WASH

This function recommends the cleaning programme that best suits the degree of contamination. The **ecocombi** has 5 easy-to-use cleaning programmes (Fast, Rinse, Short, Medium, and Long).

MAGIC BALL

A nozzle distributes water and cleaning agent in the cooking chamber, ensuring perfect cleanliness every single time, also with low water pressure.

5 PROGRAMMES:

Fast: 2 min / With water only, for rinsing between two cooking processes

Rinsing: 20 min / With water only, for rinsing between two cooking processes

Short: 35 minutes with liquid cleaner

Medium: 43 minutes with liquid cleaner

Long: 51 minutes with liquid cleaner



ACCESSORIES

ecomax accessories	DESCRIPTION
Humidity control	Accurate setting of the humidity in the cooking chamber for perfect cooking and baking results
Fully automated cleaning system	Recommends the cleaning programme with liquid cleaner which best matches the use of the oven. ecocombi offers 5 levels: Fast 2 minutes; Rinsing 20 minutes; Short 35 minutes; Medium 43 minutes; Intensive 51 minutes.
USB interface	For recipe upload and download, HACCP data management, and software updates
Internal core temperature sensor	Permanently installed core temperature sensor
External core temperature sensor	Core temperature sensor with external socket
Internal sous-vide sensor	Permanently installed sous-vide sensor
External sous-vide sensor	Sous-vide sensor with external socket
Steam hood	When the door is opened, all waste steam and vapour is extracted and condensed
Heating kit for frame unit	The frame unit can be fully panelled and heated
Detergent holder	Practical storage space for the 5-litre detergent container.
Low frame unit for TWIN version	This frame unit ensures that your two convection steamers are stacked at the proper height.
Stacking kit 4 to 6 or 10	Connection of two stacked convection steamers
Suspension frame 60 x 40 mm	Simply change the suspension frame and use baker's dimensions
Spray hose kit, loose	Spray hose mounted externally
Frame unit height adjustment kit	10 cm height increase possible

FEATURES

ecomcombi	4x 1/1	6x 1/1	10x 1/1
Number of tray shelves	4	6	10
OPERATING MODES			
Saturated steam at 98 °C	●	●	●
Low-temperature steam from 30 to 97 °C	●	●	●
Superheated steam from 99 to 105 °C	●	●	●
Hot air from 0 to 250 °C	●	●	●
Combination steam from 30 – 250 °C (with adjustable humidity control from 0 – 99%)	●	●	●
Regeneration	●	●	●
Delta-T	●	●	●
FEATURES			
Diagonal insertion	●	●	●
EN (baker's dimensions)	○	○	○
Inspection window	●	●	●
Humidity control	○	○	○
Fully automated cleaning	○	○	○
Core temperature sensor	○	○	○
Sous-vide sensor	○	○	○
Memory for 60 programmes	●	●	●
6 fan speeds	●	●	●
Reversing fan	●	●	●
HACCP data	●	●	●
Language selection	●	●	●
Pull-out spray	○	○	○
Foldable interior screen	●	●	●
Cool Down	●	●	●
USB port	○	○	○

● Included ○ Optional

DRAWINGS

Model HECME4 4 x 1/1 GN

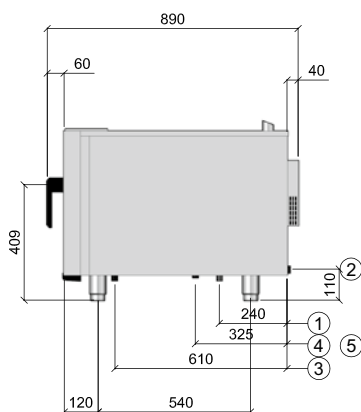
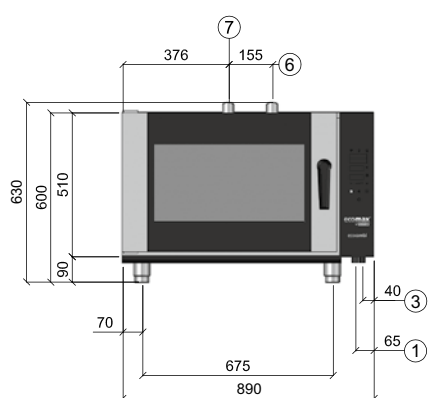

- ① Fresh water connection
- ② Drain connection
- ③ Electrical cable supply
- ④ Suction hose for detergent
- ⑤ Connection to equipotential bonding
- ⑥ Ventilation
- ⑦ Ventilation nozzle

Model HECME6 6 x 1/1 GN

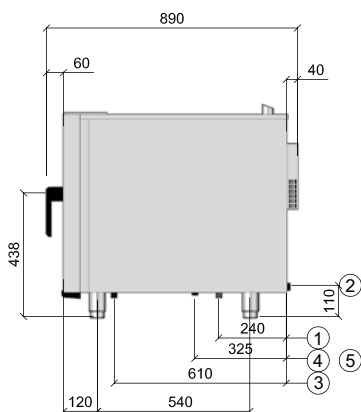
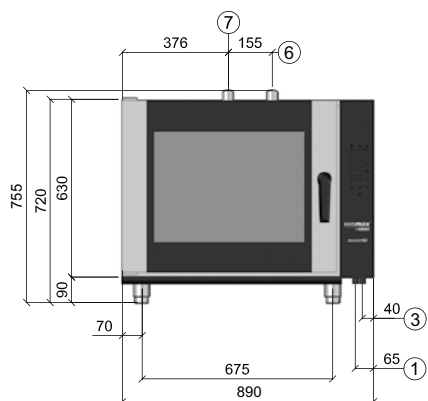

Model HECME10 10 x 1/1 GN

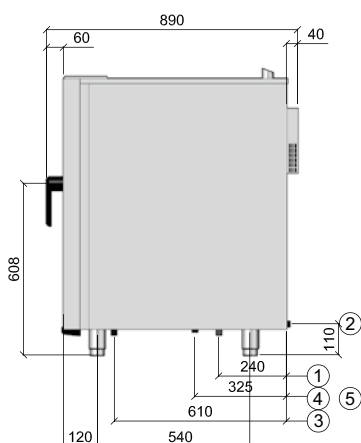
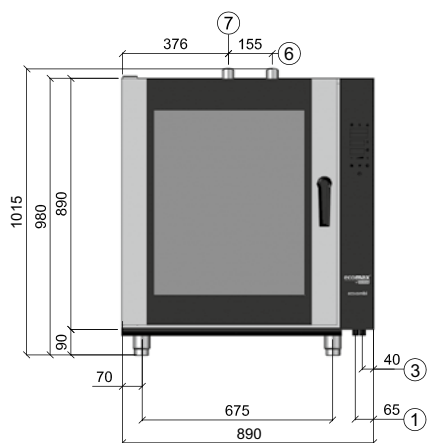

TECHNICAL SPECIFICATIONS

ecomcombi	041E	061E	101E
MODELS	HECME4	HECME6 *	HECME10 *
Capacity	4 x 1/1 GN	6 x 1/1 GN	10 x 1/1 GN
Number of meals per day	20 – 50	40 – 100	80 – 150
Guide rail distance	70 mm	70 mm	70 mm
Width	890 mm	890 mm	890 mm
Depth	890 mm	890 mm	890 mm
Height	600 mm	720 mm	980 mm
Net weight	100 kg	120 kg	160 kg
Fresh water connection	3/4"	3/4"	3/4"
Drain connection	1"	1"	1"
Flow pressure	2-4 bar	2-4 bar	2-4 bar
Recommended water hardness	0-3° dH	0-3° dH	0-3° dH
Total connected load	6 kW 8.7 A	9.5 kW 13.7 A	18.5 kW 26.7 A
Voltage	400 / 50 / 3N-PE	400 / 50 / 3N-PE	400 / 50 / 3N-PE
Electrical wiring	M32	M32	M32
Connection to equipotential bonding	M6	M6	M6
Spray protection type	IPX5	IPX5	IPX5
Noise	<70dB(A)	<70dB(A)	<70dB(A)

* All models also available as gas version

**A registered brand of HOBART GmbH
A company of the ITW Group**

Robert-Bosch-Straße 17 · 77656 Offenburg · info@ecomaxbyhobart.de

Phone +49 (0) 1803 32 66 29 (9 ct/min) · Fax +49 (0) 781 600 11 39

www.ecomaxbyHOBART.de

The details given in this brochure are correct as of 02/2017.
We reserve the right to technical or design modifications.