



COOKING  
COMBI STEAMER

**HOBART COMBI**



**HOBART  
SMART COOKING  
SOLUTION**

# HOBART

There are lots of  
combi steamers...

**But there is only one  
HOBART COMBI**



**Quality you  
can rely on!**

HOBART is synonymous with high quality as well as economical and innovative technology in the professional kitchen. Our combi steamers COMBI and COMBI-plus share the same core qualities. These two product lines are intended for all applications where top performance is required and that highest demands are met.

**Rely on HOBART's many years of experience and profound know-how. Let us focus on the technology so that you can focus on making your guests happy!**



# COOKING



## HOBART SMART COOKING SOLUTION



**Constantly perfect cooking results – You are the chef, you decide how things should be done!**

**AirControl:** Infinitely variable setting of the fan speed for precise results and optimum heat distribution – for uniform browning, evenly cooked soufflés and sponges with a perfectly level surface.

**Extra-quick and easy cleaning – also in between cooking sessions!**

At the press of a button your new combi steamer rapidly engages the fully automatic cleaning system, taking just 19 minutes to provide a professional clean.



**Simplest of operation, no mistakes – who needs complicated when things can be so easy?!**

Our FastPAD is designed to provide simple and intuitive operation. Easy selection among 250 saved programs, also via pictures.

Thanks to the smart CoreControl, your HOBART COMBI sets the parameters automatically to match the quantity and type of the dish you are preparing.

Our highly practical 'side-ways' loading and unloading of trays is the safest and most ergonomic.

**Economical – for perfect cost control!**

You can record all operating costs and need not spend any more than is necessary on operating and maintenance costs. Your oven is highly economical due to the high efficiency features of **CoreControl**, saving you up to 15% of energy costs, and **JetControl** up to 30% on water usage.



# HOBART

## An overview of all models: The perfect solution for every taste

### HOBART COMBI or COMBI-plus?

A team inside a professional kitchen need to deliver high quality food time after time and this is where the HOBART COMBI is fast and reliable.

In addition to all the benefits of the HOBART-COMBI, the HOBART COMBI-plus has features which make it more than easy for all operators to achieve the expected result. Via the FastPAD control, it is very easy to save images of your cooking processes. Your COMBI comes with a standard 70+ different programmes and regardless of who is operating the combi steamer constant cooking results is guaranteed.

Cleaning the HOBART COMBI-plus is as easy as it can get: Select the cleaning level, start the machine – and that's it. No need to fill in detergent, count cleaning tabs, spray-clean by hand, or rinse and wipe. With 19 minutes only, the unique cleaning system of the COMBI-plus furthermore has the shortest-ever runtime; the Intensive Programme saves up to 50% water compared to traditional systems.

**Whether COMBI or COMBI-plus:  
You'll always make the right decision!**

HOBART **COMBI-mini**



#### Easy

Faster start of the oven thanks to the VisioPAD in the COMBI and the FastPAD in the COMBI-plus. The operating panel is simple and intuitive. The interior of the COMBI is highly visible due to bright LED lighting. And 'side-ways' insertion of the trays provides the safest and ergonomic loading.

#### Fast

Lose no time when cooking: The Cool-Down function for quick temperature adjustment allows for continuous cooking without waiting. And if time is of the essence, you can reduce the cleaning time between the individual cooking processes.

#### Reliable

Set and monitor all parameters in the Toolbox of the HOBART COMBI-plus. Fault messages are indicated digitally. Our TwinControl feature means in the event of major operating panel damage you can still keep cooking in convection mode – the perfect back-up.

#### Economical

Save water and electricity thanks to the time-proven injection technology form of steam generation, the unique closed circuit cleaning system and automated power regulation.

FROM CONCEPT TO REALISATION

# COOKING

HOBART **COMBI**



HOBART **COMBI-plus**



HOBART **COMBI TWIN**



HOBART **COMBI TOWER**



# HOBART

## Optimum cooking result



## Even and perfect browning

### AirControl

- Auto Reverse fan: Infinitely adjustable fan impeller for perfectly even cooking (fan impeller speed adjustable from 0 to 100%)
- In the floor-mounted unit COMBI/COMBI-plus, 3 fans ensure even and fast heat distribution in the cooking chamber
- With damper for de-humidification of the cooking chamber
- With the Cool-Down feature there is fast change between operating modes utilizing either water or air, whilst the door remains closed.

- An open protective guard before the big fan impeller allows for even and fast heat distribution in the cooking chamber
- Gentle slow cooking with sous-vide core temperature sensor / Rotisserie sensor for perfect and reproducible cooking results
- Thanks to the fan impeller position at the rear of the cooking chamber, the heat reaches the food quickly



### 7 operating modes

- Low-temperature cooking with steam (30 to 97 °C)
- Saturated steam 98 °C
- Hot air up to 250 °C
- Overheated steam (99 to 105 °C)
- Combi steam from 30 – 250 °C
- Regeneration programme
- Delta-T cooking (COMBI-plus)

# COOKING



## Evenly cooked to perfection

Independent of their height and position in the combi steamer, meat, gratins, vegetable, and baked goods are evenly cooked.

A core temperature sensor is provided to ensure highly precise cooking and a tender, soft and moist consistency of the finished product.

To prevent excessive temperatures and guarantee an accurate cooking process, the COMBI-plus automatically controls the heating performance to match the food that you are preparing.

The humidity is accurately controlled simply by dialling the required percentage, to create your ideal cooking environment. The finest control of humidity is at your fingertips.

# HOBART

## Easy and comfortable

Ready for operation in an instant thanks to great user friendliness

- Simple, intuitive operating panel
- Comfortable viewing window
- Crosswise insertion for safe and ergonomic loading

Up to 33% larger viewing window

## Everything at a glance

Thanks to the large viewing window and the LED-lit interior, you see at a glance whether the food in the combi steamer is ready – even from a distance.

**The window in the door is 33% larger than that of a 10 tray oven with 'front- to -back' loading.**



## Ergonomic and safe

The 'side-ways' loading and unloading feature of the HOBART COMBI and COMBI-plus makes cooking with the oven as ergonomically friendly as possible and it is safer too!



# COOKING

**Extra easy operation thanks to the readily accessible, easy to read, intuitive operating panel.**

**No effort, no explanations**

Using the glass touch screen is child's play. Start cooking at the press of a button!

**Setting the HOBART COMBI is easy**

More than 70 saved recipes that can be adjusted individually to the core temperature of the product and to the desired degree of browning (COMBI-plus).

Develop your own creation, generate your own recipes and save them together with a picture, for fast recall (COMBI-plus).

**Ready for start-up in 3 seconds**

**Guaranteed results – perfectly reproducible**

You can program up to 100 personal recipes! Via the integrated library, select how you wish to see them for selection: either as text, or as photos.



Every day, each cooking process is recorded for display in graphic form as data, able to be accessed via USB interface.

Cooking programmes saved in FastPAD with the associated photo make sure that every user will be able to prepare the dish successfully.

**Very easy to use**



# HOBART

## Fast and easy processes

### Forget the annoying wait: The combi steamer is ready to cook in a jiffy

- Say goodbye to boiler heating tanks thanks to state-of-the-art injection technology.
- **CoreControl** with direct temperature increase (one degree per second) provides for quick automatic adjustment to the desired temperature and the quantity of the food. Thus, there is no waiting between two cooking processes.
- Save time by combining different cooking methods (up to 6 steps per recipe).
- **JetControl** quickly cools the cooking chamber down when required – via water or air, and with the door closed. Steam or heat does not escape into your kitchen.

So that you can focus on cooking...



### Easy to clean: Fast, automatic, economical



#### **2 seconds are enough to start a cleaning cycle!**

When you are ready to clean the oven between or after services, the cleaning programme of your choice takes just two seconds to activate.



# COOKING



## Cleaning programmes

Basic Programme.....	19 min
Medium Programme .....	25 min
Intensive Programm .....	35 min
Conventional programmes .....	123 min

### **Fastest fully automated cleaning programme:**

Between prepping and lunch or dinner service, you need less than half an hour to clean the HOBART COMBI.

Program the cleaning process for a whole week by selecting a time and wash cycle. Now, the combi steamer will do everything automatically.

### **Sparklingly clean**

Economical and ecological cleaning with HOBART, the specialist for cleanliness and hygiene.

### **No contact with the detergent.**

Chemical is supplied directly via the fully automated cleaning system, meaning no operator is required to handle cleaning tablets or cartridges and with a better cleaning result too! The operator does not have to touch cleaning tabs or cartridges.

### **Shorter cleaning cycles:**

Cleaning takes less than half the time than with other combi steamers: Duration of the intensive cleaning cycle of the COMBI-plus is 41 minutes.

# HOBART

## Clean and economical Save water, energy, and cleaner!

With CoreControl the oven automatically scales back the energy input as the set temperature is reached, reducing energy consumption by one-third.

**No loss of energy thanks to a clever combination of cooking methods together with high temperature accuracy.**

The direct steam injection prevents unnecessary consumption of water and electricity. Since the combi steamer does without long pre-heating, there is no increased energy consumption in standby mode.

**COMBI and COMBI-plus help you to save money without any effort.**



# COOKING

## CLEANING PROGRAMME:

The closed circuit system cleaning process helps you to save water and thus also cleaner: up to 50 liters of water per cleaning cycles in the 20 x 2/1 floor-mounted unit.



Significantly reduced energy costs thanks to a connected load that is 22% lower than that of comparable units.



Economical –  
for perfect cost  
control!



# HOBART

## Superior reliability and useful life

### Work safely with the auto-diagnosis system



#### **TwinControl**

In case of a display failure, the unit automatically switches to convection mode to finish the cooking process at 180 °C. Should the touch display be at fault, you can still control the unit by means of the rotary knob.

Automatic diagnosis of water quality:

The combi steamer warns you when the water quality is decreasing.

The HOBART COMBI indicates when the water filter needs replacing.

The integrated software makes access to all HACCP relevant data very easy (COMBI-plus).



Thanks to the crosswise insertion, the chef does not need to reach into the cooking chamber and does not risk burn injuries.

# COOKING



**Sturdy and reliable**  
Your COMBI will never let you down!

**IN CASE OF FAULT,  
THE EMERGENCY PROGRAMME KICKS IN:**

**A trolley cart smashes against the oven door  
heavily damaging the operating panel**

**Your COMBI has a fall back solution.**

Simply close the door three times to trigger “Emergency Mode” which allows for ongoing cooking in convection mode at 180C. You can continue cooking.

Use the keyboard in the screen to continue setting cooking programmes, or touch the panel to increase or decrease the temperature.

**THE COOLING SYSTEM  
IN THE TECHNOLOGY SECTION IS SOILED!**

To prevent overheating, the combi steamer limits the cooking temperature and indicates that the dirt filter below the operating panel needs cleaning.

**Twin Control system for 100% operational reliability**





More space,  
more time

### COMBI TOWER

Pressure steam cooker  
combined with combi steamer

#### A SOLUTION THAT IS UNIQUE ON THE MARKET:

Speed and versatility on just one square meter!

#### Pressure steam cooker:

Gentle, healthy cooking to preserve nutritional value, natural taste and appearance of the produce. Reduce production times and finish work earlier thanks to the powerful performance of your COMBI TOWER.

#### RECORD COOKING TIMES

Fish 2 min.	
Chicken 1:20 min	
Potatoes 8 min.	

### HOBART COMBI:

Combi steamer with 6 cooking methods. The COMBI is a versatile production unit particularly suitable for cooking gratins and baked goods, as well as meat using low-temperature or vacuum technique.

COMBI ensures even cooking with uniform browning and highly accurate low-temperature cooking.

The combination of the pressure steam cooker and the COMBI meets all expectations on a floor space of just one square meter.



Small footprint  
Less loss  
Less time  
Gentle on the produce

# COOKING



## COMBI-mini Compact on a small footprint

Whether as a combi steamer in the restaurant kitchen, in the lunch room of an office building, or in a pub or bistro – the COMBI-mini is the perfect solution when you are looking for high performance on the smallest floor space.

**COMBI-mini offers the benefits of a full-sized unit on a very small floor space.**

**The baking and cooking performance of a HOBART COMBI in compact design!**

The COMBI-mini is available as a stand-alone unit or as TWIN.





# Accessories, equipment & technical data

## Accessories

Item number	Description
ACM6H	Steam extractor hood for COMBI-mini 061
ACM6PT	Frame COMBI-mini 061
ACKPSC	Core temperature sensor connection set
ACKUSB	USB port set
ACSC	3-point core temperature sensor Rôtisserie
ACSCF	1-point sous-vide temperature sensor
AC6-11HE	Steam extraction hood for COMBI/COMBI-plus 061/101
AC202CB102	Banquet trolley for COMBI/COMBI-plus 202 (102 plates, 75 mm)
AC6-1KDE	Spray, with automated retract function
OPELA	Fully automated cleaning for COMBI
AC20KF	Grease filter kit for COMBI/COMBI-plus 201/202

## Features

Models	COMBI-plus	COMBI	COMBI-mini
Crosswise insertion	●	●	–
Inspection window	●	●	–
LED lamps	●	●	●
VisioPAD operation	–	●	●
FastPAD operation	●	–	–
3 mm glass touch display	●	●	●
AirControl	●	●	●
JetControl	●	●	●
CoreControl	●	●	●
TwinControl	●	●	●
Fully automated cleaning	●	○	●
Standard cleaning	–	●	–
Core temperature sensor	●	○	○
Sous-vide probe	○	○	○
HACCP data	●	●	●
Language selection	●	●	●
Pullout spray	○	○	○
Folding interior screen	●	●	●
Cool-Down	●	●	●
USB	●	○	○

● Included

○ Optional

– Not available



# COOKING

## Technical data (COMBI-plus / COMBI)

MODELS	COMBI-plus				
	061E *	101E *	102E *	201E *	202E *
Capacity	6 x 1/1 GN	10 x 1/1 GN	10 x 2/1 GN	20 x 1/1 GN	20 x 2/1 GN
Number of meals per day	40 – 100	80 – 150	130 – 200	160 – 300	250 – 400
Guide rail distance	83 mm	67 mm	67 mm	65 mm	65 mm
Width	920 mm	920 mm	920 mm	990 mm	990 mm
Depth	846 mm	846 mm	1,171 mm	862 mm	1,187 mm
Height	899 mm	1,069 mm	1,069 mm	1,947 mm	1,947 mm
Net weight	110 kg	125 kg	145 kg	241 kg	268 kg
Fresh water supply	max. 23 °C	max. 23 °C	max. 23 °C	max. 23 °C	max. 23 °C
Drain connection	G 1" 1/2	G 1" 1/2	G 1" 1/2	G 1" 1/2	G 1" 1/2
Flow pressure	1.5 – 6 bar	1.5 – 6 bar	1.5 – 6 bar	1.5 – 6 bar	1.5 – 6 bar
Recommended water hardness	0 – 3° dH	0 – 3° dH	0 – 3° dH	0 – 3° dH	0 – 3° dH
Total connected load	9.3 kW   14.3 A	15.3 kW / 23 A	24.3 kW / 36.1 A	27.7 kW / 42.2 A	54.7 kW / 81.3 A
Fuse protection	3 x 16 A	3 x 25 A	3 x 50 A	3 x 50 A	3 x 100 A
Voltage	400/50/3N-PE	400/50/3N-PE	400/50/3N-PE	400/50/3N-PE	400/50/3N-PE
Electrical cable supply	M32	M32	M40	M63	M63
Connection to equipotential bonding	M5	M5	M5	M5	M5
Spray protection type	IP25	IP25	IP25	IP25	IP25
Noise development	<70dB(A)	<70dB(A)	<70dB(A)	<70dB(A)	<70dB(A)

MODELS	COMBI				
	061 E / EB *	101 E / EB *	102 E *	201 E / EB *	202 E / EB *
Capacity	6 x 1/1 GN	10 x 1/1 GN	10 x 2/1 GN	20 x 1/1 GN	20 x 2/1 GN
Number of meals per day	40 – 100	80 – 150	130 – 200	160 – 300	250 – 400
Guide rail distance	83 mm	67 mm	67 mm	65 mm	65 mm
Width	920 mm	920 mm	920 mm	990 mm	990 mm
Depth	846 mm	846 mm	1,171 mm	862 mm	1,187 mm
Height	899 mm	1,069 mm	1,069 mm	1,947 mm	1,947 mm
Net weight	110 kg	125 kg	145 kg	241 kg	268 kg
Fresh water supply	max. 23 °C	max. 23 °C	max. 23 °C	max. 23 °C	max. 23 °C
Drain connection	G 1" 1/2	G 1" 1/2	G 1" 1/2	G 1" 1/2	G 1" 1/2
Flow pressure	1.5 – 6 bar	1.5 – 6 bar	1.5 – 6 bar	1.5 – 6 bar	1.5 – 6 bar
Recommended water hardness	0 – 3° dH	0 – 3° dH	0 – 3° dH	0 – 3° dH	0 – 3° dH
Total connected load	9.3 kW   14.3 A	15.3 kW / 23 A 15.8 kW / 23.8 A	24.3 kW	27.7 kW / 42.2 A	54.7 kW / 81.3 A
Fuse protection	3 x 16 A	3 x 25 A	3 x 50 A	3 x 50 A	3 x 100 A
Voltage	400/50/3N-PE	400/50/3N-PE	400/50/3N-PE	400/50/3N-PE	400/50/3N-PE
Electrical cable supply	M32	M32	M40	M63	M63
Connection to equipotential bonding	M5	M5	M5	M5	M5
Spray protection type	IP25	IP25	IP25	IP25	IP25
Noise development	<70dB(A)	<70dB(A)	<70dB(A)	<70dB(A)	<70dB(A)

E = electrical; EB = electrical boiler

\* All models also available as gas version



# Drawings & technical data

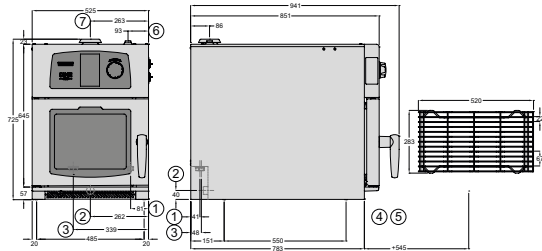

COMBI-mini 061E

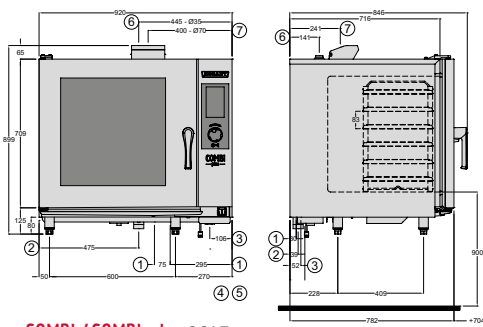

COMBI / COMBI-plus 061E

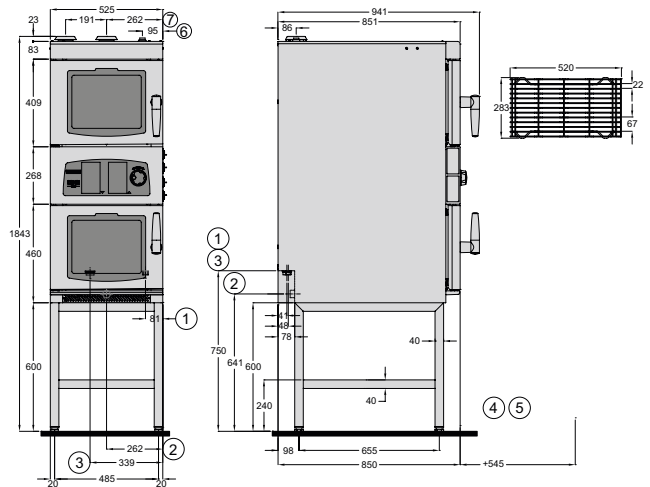

COMBI-mini 661E TWIN

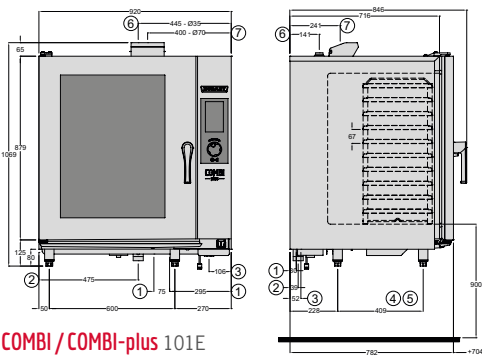

COMBI / COMBI-plus 101E

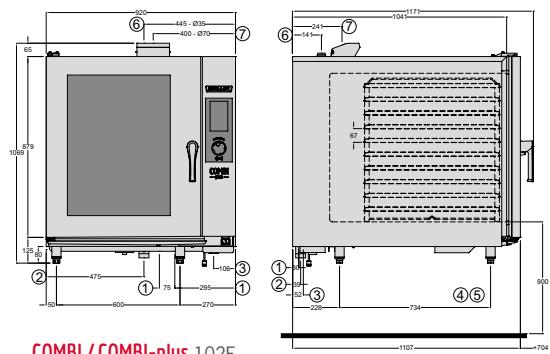

COMBI / COMBI-plus 102E

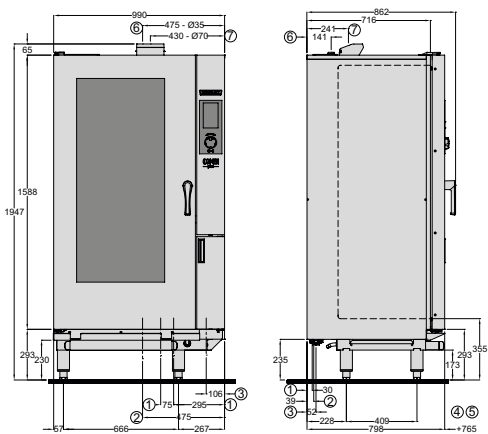

COMBI / COMBI-plus 201E

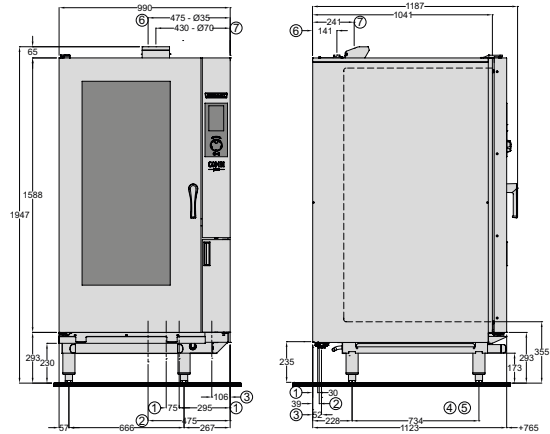

COMBI / COMBI-plus 202E

# COOKING

## Technical data (TWIN und COMBI-mini)

MODELS	COMBI-plus		COMBI		COMBI-mini	
	611E (TWIN)	661E (TWIN)	611E (TWIN)	661E (TWIN)	061E	661E (TWIN)
Capacity	16 x 1/1 GN	12 x 1/1 GN	16 x 1/1 GN	12 x 1/1 GN	6 x 1/1 GN (20 mm)	12 x 1/1 GN (20 mm)
Number of meals per day	80 – 160	80 – 120	80 – 160	80 – 120	20 – 40	40 – 80
Guide rail distance	83/67 mm	83 mm	83/67 mm	83 mm	22 mm	22 mm
Width	920 mm	920 mm	920 mm	920 mm	525 mm	525 mm
Depth	887 mm	887 mm	887 mm	887 mm	941 mm	941 mm
Height	1,945 mm	1,825 mm	1,945 mm	1,825 mm	725 mm	1,843 mm
Net weight	216 kg	205 kg	216 kg	205 kg	72 kg	143 kg
Fresh water supply	max. 25°C	max. 25°C	max. 25°C	max. 25°C	max. 25°C	max. 25°C
Drain connection	G 1" 1/2	G 1" 1/2	G 1" 1/2	G 1" 1/2	1"	1"
Flow pressure	1.5 – 6 bar	1.5 – 6 bar	1.5 – 6 bar	1.5 – 6 bar	1.5 – 6 bar	1.5 – 6 bar
Recommended waterhardness	0 – 3° dH	0 – 3° dH	0 – 3° dH	0 – 3° dH	0 – 3° dH	0 – 3° dH
Total connected load	24.6 kW /37.4 A	18.6 kW /28.7 A	24.6 kW /37.4 A	18.6 kW /28.7 A	6.3 kW / 10.4 A	12.5 kW /19.6 A
Fuse protection	3 x 50 A	3 x 32 A	3 x 50 A	3 x 32 A	3 x 16 A	3 x 20 A
Voltage	400/50/3N-PE	400/50/3N-PE	400/50/3N-PE	400/50/3N-PE	400/50/3N-PE	400/50/3N-PE
Electrical cable supply	M40	M40	M40	M40	M25	M32
Connection to equipotential bonding	M5	M5	M5	M5	M5	M5
Spray protection type	IP25	IP25	IP25	IP25	IP25	IP25
Noise development	<70dB(A)	<70dB(A)	<70dB(A)	<70dB(A)	<70dB(A)	<70dB(A)

E = electrical

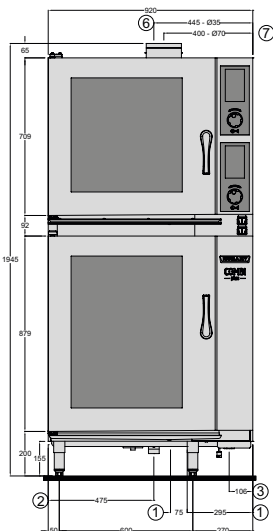

COMBI / COMBI-plus 611E TWIN

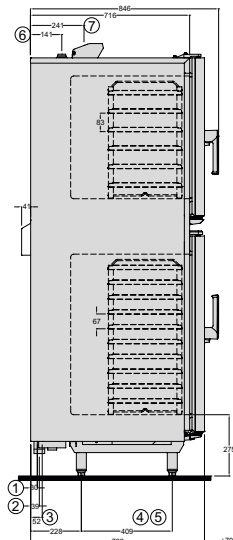

COMBI / COMBI-plus 661E TWIN

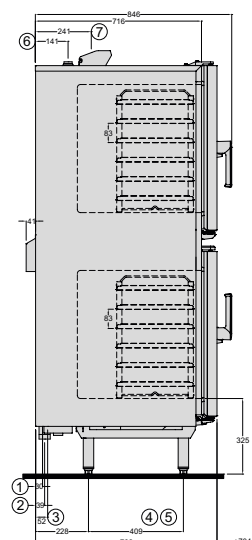
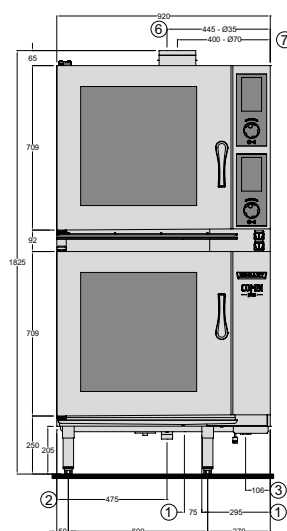



## THE COMPANY

HOBART is the world market leader for commercial warewashing technology and well-known manufacturer of cooking, food preparation, and environmental technology. Founded 1897 in Troy, Ohio, HOBART today has a global workforce of more than 6,900. All over the world, the hotel and catering trade, cafeterias, bakeries and butcher shops, supermarkets, airlines, cruise ships, automotive suppliers, research centres and pharmaceutical companies swear by our innovative products, which are considered to be economical and ecological market leaders.



# COOKING

## OUR FOCUS

### INNOVATIVE - ECONOMICAL - ECOLOGICAL

Every year, HOBART applies for a many patents. This makes us the exception in our industry. However, innovation means more to us than a number of patents. Being innovative means that we can make work easier for you and help you save costs and resources. We offer you added value. This is not only our own opinion but also that of many happy customers, evidenced by various prizes we are awarded every year. Economic efficiency means that we as innovation leader set standards for operating costs and resource consumption. This helps you and our environment. Sustainability means that we act responsibly when consuming resources. This is true not only for the operation of our products but also for the entire company, from sourcing over production up to logistics. At our Offenburg site, for example, we are only using green electricity. At HOBART, sustainability has a name: CO2NSEQUENT.

## HOBART

### COMPETENT - FAST - RELIABLE

HOBART service technicians as well as HOBART service partners are the “real experts“. Thanks to intensive training and many years of experience, they have a unique and profound knowledge of the products. This means that maintenance and repair work is therefore always carried out professionally, fast and reliably.



# BART

**DEUTSCHLAND/ÖSTERREICH****HOBART GMBH**

Robert-Bosch-Straße 17 | 77656 Offenburg  
Tel.: +49(0)781.600-0 | Fax: +49(0)781.600-23 19  
info@hobart.de | www.hobart.de



Werkskundendienst 0180.345 62 58  
für Österreich 0820.24 05 99

Zentraler Verkauf 0180.300 00 68

**SCHWEIZ****GEHRIG GROUP AG**

Bäulerwisenstrasse 1 | 8152 Glattbrugg  
Tel.: +41(0)43.211 56-56  
Fax: +41(0)43.211 56-99  
info@gehriggroup.ch  
www.gehriggroup.ch

**FRANCE****COMPAGNIE HOBART**

ZI PARIS EST - Allée du 1er Mai - B.P. 68  
77312 MARNE LA VALLEE Cedex 2  
Téléphone: +33(0)1 64 11 60 00  
Fax: +33(0)1 64 11 60 01  
contact@hobart.fr  
www.hobart.fr

**UNITED KINGDOM****HOBART UK**

Southgate Way | Orton Southgate  
Peterborough | PE2 6GN  
Phone: +44(0)844 888 7777  
customer.support@hobartuk.com  
www.hobartuk.com

**BELGIUM****HOBART FOSTER BELGIUM**

Industriestraat 6 | 1910 Kampenhout  
Phone: +32(0)16 60 60 40  
Fax: +32(0)16 60 59 88  
sales@hobart.be  
www.hobart.be

**NEDERLAND****HOBART NEDERLAND B.V.**

Pompmolenlaan 12 | 3447GK Woerden  
Tel.: +31(0)348.46 26 26  
Fax: +31(0)348-43 01 17  
info@hobart.nl  
www.hobart.nl

**NORGE****HOBART NORGE**

Gamle Drammensvei 120 A | 1363 HØVIK  
Tel.: +47 67 10 98 00  
Fax: +47 67 10 98 01  
post@hobart.no  
www.hobart.no

**SVERIGE****HOBART SCANDINAVIA APS**

Box 2101 | 196 02 Kungsängen  
Tel.: +46 8 584 50 920  
Fax: +46 8 584 50 929  
info@hobart.se  
www.hobart.se

**DANMARK****HOBART SCANDINAVIA APS**

Håndværkerbyen 27 | 2670 Greve  
Tel.: +45 43 90 50 12  
Fax: +45 43 90 50 02  
post@hobart.dk  
www.hobart.dk

**AUSTRALIA****HOBART FOOD EQUIPMENT**

Unit 1 / 2 Picken Street | Silverwater NSW | 2128  
Tel.: +61(0)2 9714 0200  
Fax: +61(0)2 9714 0242  
www.hobartfood.com.au

**KOREA****HOBART KOREA LLC**

7th Floor | Woonsan Bldg | 108 | Bangi-dong  
Songpa-gu | Seoul 138-050  
Phone: +82(0)2 34 43 69 01  
Fax: +82(0)2 34 43 69 05  
contact@hobart.co.kr  
www.hobart.co.kr

**JAPAN****HOBART (JAPAN) K.K.**

Suzunaka Building Omori  
6-16-16 Minami-Oi | Shinagawa-ku | Tokyo 140-0013  
Phone: +81(0)3 5767 8670  
Fax: +81(0)3 5767 8675  
info@hobart.co.jp  
www.hobart.co.jp

**SINGAPORE****HOBART INTERNATIONAL (S) PTE LTD**

158 | Kallang Way | #06-03/05  
Singapore 349245  
Phone: +65(0)6846 7117  
Fax: +65(0)6846 0991  
enquiry@hobart.com.sg  
www.hobart.com.sg

**THAILAND****HOBART (THAILAND)**

889 Thai CC building | 31st Floor | Room no. 311  
South Sathorn Rd. | Yannawa | Sathorn  
Bangkok 10120  
Phone: +66(0)2-675-6279 | Fax: +66(0)2-675-6280  
enquiry@hobartthailand.com | www.hobartthailand.com

**OTHER COUNTRIES****HOBART GMBH**

Robert-Bosch-Straße 17 | 77656 Offenburg | Germany  
Phone: +49(0)781.600-28 20  
Fax: +49(0)781.600-28 19  
info-export@hobart.de  
www.hobart-export.com

Die Angaben in diesem Prospekt beruhen auf dem Stand 02/2017. Technische Änderungen oder Änderungen der Ausführung bleiben vorbehalten.

The details given in this brochure are correct as of 02/2017. We reserve the right to technical or design modifications.

Document non contractuel. Les indications de ce prospectus sont conformes à la mise à jour de 02/2017. Nous nous réservons le droit de modifier les données ou les configurations techniques de nos machines.

